

Multitel MX290EX

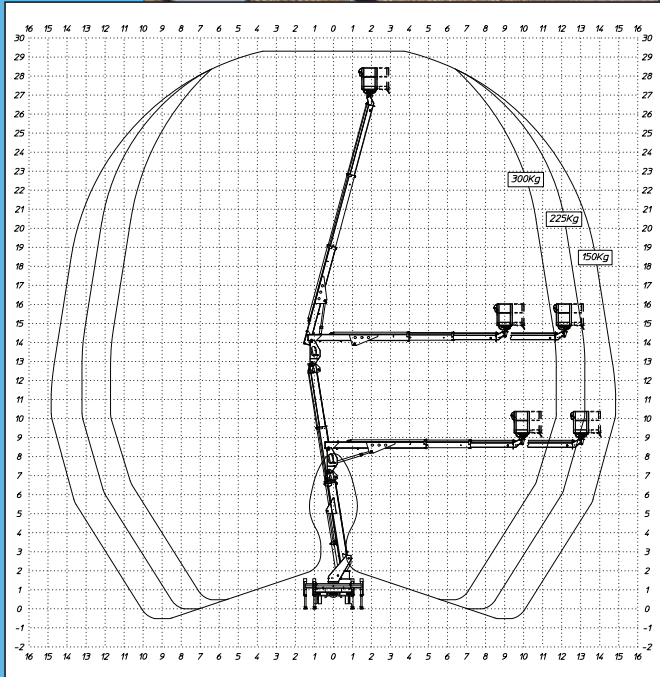

MULTITEL MX290EX

Specification	Metric	Imperial
Working Height	29.30m	96ft 2in
Platform Height	27.30m	89ft 7in
Max Outreach	14.90m	58ft 9in
Safe Working Load (SWL)	300kg	660lb
Length	7.90m	25ft 11in
Width	2.95m	9ft 8in
Width (Stowed)	1.99m	6ft 6in
Height	2.93m	9ft 8in
Weight	7,500kg	16,535lb
Power Source	Diesel	



CASE STUDY

NATURE OF JOB:

To fix broken slates on a church roof and pointing on the gables.

REASON FOR CHOOSING THIS MACHINE:

Good outreach on a lightweight truck-mounted machine, variable jacking, compact and easy to set up in a tight location. A much more cost effective alternative to scaffolding.

CHALLENGE:

To access a church roof with no immediate area in the church grounds to set up a machine. Only access was from a narrow road, so good outreach on a lightweight machine was essential. There were also obstacles, so up and over clearance needed.

EQUIPMENT:

Multitel MX290EX

SOLUTION

Our experienced staff surveyed the job and knew that the compact footprint and variable jacking of the Multitel MX290EX would allow the operator to set up the machine on the footpath outside. The superior outreach meant the operator could easily access the roof from its stable set up position and carry out their work on the roof. The customer was able to complete the job faster and more cost effectively than they would have with scaffolding, saving time and money.



MULTITEL MX290EX

29m